



Space product assurance

Requirements for manufacturing and procurement of threaded fasteners

ECSS Secretariat
ESA-ESTEC
Requirements & Standards Division
Noordwijk, The Netherlands

Foreword

This Standard is one of the series of ECSS Standards intended to be applied together for the management, engineering and product assurance in space projects and applications. ECSS is a cooperative effort of the European Space Agency, national space agencies and European industry associations for the purpose of developing and maintaining common standards. Requirements in this Standard are defined in terms of what shall be accomplished, rather than in terms of how to organize and perform the necessary work. This allows existing organizational structures and methods to be applied where they are effective, and for the structures and methods to evolve as necessary without rewriting the standards.

This Standard has been prepared by the ECSS Executive Secretariat, endorsed by the Document and Discipline Focal points, and approved by the ECSS Technical Authority.

Disclaimer

ECSS does not provide any warranty whatsoever, whether expressed, implied, or statutory, including, but not limited to, any warranty of merchantability or fitness for a particular purpose or any warranty that the contents of the item are error-free. In no respect shall ECSS incur any liability for any damages, including, but not limited to, direct, indirect, special, or consequential damages arising out of, resulting from, or in any way connected to the use of this Standard, whether or not based upon warranty, business agreement, tort, or otherwise; whether or not injury was sustained by persons or property or otherwise; and whether or not loss was sustained from, or arose out of, the results of, the item, or any services that may be provided by ECSS.

Published by: ESA Requirements and Standards Division
ESTEC, P.O. Box 299,
2200 AG Noordwijk
The Netherlands

Copyright: 2008 © by the European Space Agency for the members of ECSS

Change log

ECSS-Q-70-46A 21 January 2000	First issue Transforming ESA PSS-01-746 into an ECSS Standard
ECSS-Q-70-46B	Never issued
ECSS-Q-ST-70-46C 31 July 2008	Second issue Redrafting of ECSS-Q-70-22A according to new ECSS drafting rules and template. In particular: <ul style="list-style-type: none">• The requirements of the original clauses 4, 5, 6 and 7 were moved to the clauses 4.1 to 4.4.• From the sections 4.3.7 and 4.3.8 the requirements which do not fit there were moved to section 4.1.2 as requirements 4.1.2d and 4.1.2e.• From the original section 7.2.5 a DRD was created and moved to the normative Annex B.• Table 2 was moved to the informative Annex C.• The section 4 “Principles” was deleted.

Table of contents

Change log	3
1 Scope	6
2 Normative references	7
3 Terms, definitions and abbreviated terms	9
3.1 Terms defined in other standards.....	9
3.2 Terms specific to the present standard	9
3.3 Abbreviated terms	10
4 Requirements	11
4.1 Fabrication.....	11
4.1.1 General.....	11
4.1.2 Raw material.....	11
4.1.3 Head forming.....	11
4.1.4 Heat treatment.....	12
4.1.5 Head-to-shank fillet rolling.....	12
4.1.6 Threads	12
4.1.7 Identification marking.....	13
4.1.8 Surface treatment.....	13
4.1.9 Workmanship, handling and packaging.....	14
4.2 Dimensional and metallurgical requirements	14
4.2.1 General.....	14
4.2.2 Nominal dimensions	14
4.2.3 Head-to-shank fillet.....	15
4.2.4 Non-destructive inspections	15
4.2.5 Metallurgical examination	16
4.2.6 Measurement of hydrogen content.....	18
4.2.7 Outgassing and offgassing	18
4.3 Mechanical testing.....	18
4.3.1 General.....	18
4.3.2 Hardness test	19

4.3.3	Tensile test	19
4.3.4	Shear test	21
4.3.5	Fatigue test.....	21
4.3.6	Creep test.....	22
4.3.7	Corrosion test	23
4.3.8	Stress-corrosion test.....	23
4.4	Quality assurance.....	24
4.4.1	General.....	24
4.4.2	Quality requirements	24
Annex A (normative) Customer specification document for threaded fasteners – DRD.....		27
Annex B (normative) Product conformance report (PCR) – DRD.....		29
Annex C (informative) Inspection levels, acceptance quality limits (AQL) and limiting quality levels (LQ) for inspection of fasteners.....		30
Bibliography.....		32
Figures		
Figure 4-1: Tolerance of head-to-shank fillet profile		16
Figure 4-2: Location of microsections for metallurgical examination.....		17
Figure 4-3: Area Z delimiting interruptions in grain flow in the head-to-shank region		17
Figure 4-4: Example of a regular grain flow in a threaded surface.....		17
Figure 4-5: Locations for hardness testing (indicated with cross symbol).....		19
Figure 4-6: Loading schematic for tensile testing of threaded fasteners.....		22
Figure 4-7: Schematic of an example of double-shear loading jigs.....		23
Tables		
Table 4-1: Maximum allowed values of the extension C of the distorted area shown in Figure 4-1		16
Table C-1 : Inspection levels, acceptance quality limits (AQL) and limiting quality levels (LQ) for inspection of fasteners		30

1

Scope

This Standard defines the requirements for manufacturing, provision, inspection and quality control of high-quality threaded fastening devices (bolts, nuts, studs and screws) hereafter referred to as threaded fasteners or fasteners, used in space hardware.

This Standard does not include a complete review of the factors relevant to the fabrication of high quality threaded fasteners. It provides the definition of the technical requirements and quality control procedures to be applied in the fabrication and supply of threaded fasteners for spacecraft applications.

Fasteners for spacecraft applications are those aerospace standard fasteners (i.e. in conformance with LN, DIN or other national or international aerospace standards), or those fasteners meeting or exceeding the requirements in ISO 4759-1:2000 for "Product grade A", which also fulfil the requirements for space applications as specified in the present document.

This standard may be tailored for the specific characteristics and constraints of a space project in conformance with ECSS-S-ST-00.

2

Normative references

The following normative documents contain provisions which, through reference in this text, constitute provisions of this ECSS Standard. For dated references, subsequent amendments to, or revision of any of these publications, do not apply. However, parties to agreements based on this ECSS Standard are encouraged to investigate the possibility of applying the more recent editions of the normative documents indicated below. For undated references, the latest edition of the publication referred to applies.

ECSS-S-ST-00-01	ECSS System – Glossary of terms
ECSS-E-ST-32-01	Space engineering – Fracture control
ECSS-Q-ST-70	Space product assurance – Materials, mechanical parts and processes
ECSS-Q-ST-70-02	Space product assurance – Thermal vacuum outgassing test for the screening of space materials
ECSS-Q-ST-70-29	Space product assurance – Determination of offgassing products from materials and assembled articles to be used in a manned space vehicle crew compartment
ECSS-Q-ST-70-36	Space product assurance – Material selection for controlling stress-corrosion cracking
ECSS-Q-ST-70-37	Space product assurance – Determination of the susceptibility of metals to stress-corrosion cracking
ECSS-Q-ST-70-71	Space product assurance – Data for selection of space materials and processes
ISO 204:1997	Metallic materials – Uninterrupted uniaxial creep testing in tension – Method of test
ISO 225:1998	Fasteners – Bolts, screws, studs and nuts – Symbols and designations of dimensions
ISO 1502:1996	ISO general – purpose metric screw threads – Gauges and gauging
ISO 2859-1:1999	Sampling procedures for inspection by attributes, Part 1: Sampling schemes indexed by acceptance quality limit (AQL) for lot-by-lot inspection

ISO 2859-2:1985	Sampling procedures for inspection by attributes, Part 2: Sampling plans indexed by limiting quality (LQ), for isolated lots inspection
ISO 3353-1:2002	Aerospace — Lead and runout threads — Part 1: Rolled external threads
ISO 3800:1993	Threaded fasteners — Axial load fatigue testing — Test methods and evaluation of results
ISO 4759-1:2000	Tolerances for fasteners — Part 1: Bolts, screws, studs and nuts — Product grades A, B and C
ISO 6157-2:1995	Fasteners — Surface discontinuities — Part 2: Nuts
ISO 6157-3:1988	Fasteners — Surface discontinuities — Part 3: Bolts, screws and studs for special requirements
ISO 6506-1:1991	Metallic materials — Brinell hardness test — Part 1: Test method
ISO 6506-2:1999	Metallic materials — Brinell hardness test — Part 2: Verification and calibration of testing machines
ISO 6506-3:1999	Metallic materials — Brinell hardness test — Part 3: Calibration of reference blocks
ISO 6507-1:1997	Metallic materials — Vickers hardness test — Part 1: Test method
ISO 6507-2:1997	Metallic materials — Vickers hardness test — Part 2: Verification and calibration of testing machines
ISO 6507-3:1997	Metallic materials — Vickers hardness test — Part 3: Calibration of reference blocks
ISO 6508-1:1999	Metallic materials — Rockwell hardness test — Part 1: Test method
ISO 6508-2:1999	Metallic materials — Rockwell hardness test — Part 2: Verification and calibration of testing machines
ISO 6508-3:1999	Metallic materials — Rockwell hardness test — Part 3: Calibration of reference blocks
ISO 9140:1998	Aerospace — Nuts, plain or slotted (castellated) — Test methods
ASTM B 117-1997	Standard practice for operating salt spray (fog) apparatus
ASTM E 1417-1999	Standard practice for liquid penetrant testing
ASTM E 1444-2001	Standard practice for magnetic particle testing

3

Terms, definitions and abbreviated terms

3.1 Terms defined in other standards

For the purpose of this Standard, the terms and definitions from ECSS-S-ST-00-01 and ECSS-Q-ST-70 apply.

3.2 Terms specific to the present standard

3.2.1 bolt

cylindrical screwed bar provided with a head, generally not threaded along its entire length

NOTE For example: Shank plus threaded portion.

3.2.2 fail-safe

approach in which the structure is designed with sufficient structural redundancy to ensure that the failure of one structural element does not cause general failure of the entire structure

3.2.3 fastener

device used to hold parts firmly together in an assembly

3.2.4 galling

condition whereby excessive friction between high spots results in localized welding with subsequent splitting and a further roughening of rubbing surfaces of one or both or two mating parts

3.2.5 internal defects

voids, cracks, inclusions, gross alloy segregation and indication of overheating

3.2.6 nut

metal collar, screwed internally, to fit a bolt

NOTE Usually hexagonal in shape and operated by a spanner.

3.2.7 safe-life

approach which requires that the largest undetected defect that can exist in the structure does not grow to failure when subjected to loads and environments encountered in service

3.2.8 sampling plan

combination of sample size to be used with associated batch acceptability criteria

3.2.9 shank

unthreaded portion of the cylindrical screwed bar of a bolt

3.2.10 stud

shank, or endless bolt, externally screwed from one end, both ends or along its entire length

3.2.11 (screw) thread

helical ridge of approximately triangular, square or rounded section, formed on a cylindrical core, the pitch and core diameter being standardised under various systems

3.2.12 threaded fastener

device composed by a cylindrical screwed bar provided with a head and a metal collar, screwed internally, to fit the cylindrical bar that is used to hold parts firmly together in an assembly

3.3 Abbreviated terms

For the purpose of this Standard, the abbreviated terms from ECSS-S-ST-00-01 and the following apply:

Abbreviation	Meaning
AQL	acceptance quality level
ASTM	American Society for Testing and Materials
HB	Brinell hardness
HRC	Rockwell hardness
HV	Vickers hardness
ISO	International Organization for Standardization
LQ	limiting quality
PCR	product conformance report
PVC	polyvinyl chloride
RMC	raw material certificate
UTS	ultimate tensile strength

4 Requirements

4.1 Fabrication

4.1.1 General

- a. The customer shall establish a specification document in conformance with the DRD in Annex A.
- b. The supplier shall have a quality assurance system.
- c. The supplier shall verify and assure conformance during production to the technical requirements specified in clause 4.1.

4.1.2 Raw material

- a. The raw material for threaded fasteners shall be selected in conformance with the metallic materials requirements specified in ECSS-Q-ST-70-71, if not otherwise specified in the customer specification document for threaded fasteners.
- b. Nut material shall be more ductile than bolt material.

NOTE The reason is that during tightening nut threads can deflect to seat on the bolt threads.
- c. Materials for threaded fasteners shall be selected in order to avoid galling of the mating surfaces.

NOTE Galling in stainless steel fasteners can be prevented by using two different steels on the mating surfaces and by specific surface treatments.
- d. Materials for threaded fasteners shall be corrosion resistant
- e. Materials shall possess high resistance to stress-corrosion cracking in conformance with ECSS-Q-ST-70-36.

4.1.3 Head forming

- a. Fastener heads shall be formed by hot or cold forging before heat treating.

NOTE Driving recesses and lightening holes in double hexagon design can be forged or machined.

4.1.4 Heat treatment

- a. Headed forged blanks shall be heat treated and cold worked by rolling or drawing methods in conformance with the customer specification document for threaded fasteners and the specifications in clause 4.2 of this Standard.
- b. Forged blanks belonging to the same batch shall be heat treated in one batch.
- c. The supplier shall re-treat a batch which, tested as in 4.3.3, did not meet the mechanical property requirements, no more than twice (three times for Titanium alloys).
- d. If a different supplier produces the blanks, inspections and quality control shall be performed as specified in 4.4.2.1 under direct responsibility of the original blanks' supplier.

NOTE This is done in the case where the supplier is unable to carry out the blank fabrication as requested by the customer.

- e. Grinding of shank and head bearing surfaces of blanks to obtain roughness values as specified in 4.2.4 shall be carried out after any heat treatment.

4.1.5 Head-to-shank fillet rolling

- a. Head-to-shank fillet rolling shall be carried out after any heat treatment and machining processes.
- b. Cold rolling shall remove from the fillet surface any evidence of previous machining or etching process.
- c. Geometrical distortion of the fillet surface shall be within the limits specified in 4.2.3.

NOTE In fasteners having compound radii between head and shank, cold rolling can be extended to the remaining part of the fillet surface.

- d. There shall be no machining or etching of the fillet radius after rolling.

4.1.6 Threads

- a. External threads shall be formed by rolling process.
- b. Thread rolling shall be carried out on each fastener in one single continuous operation.
- c. When thread rolling on each fastener is not performed in one single continuous operation, the threaded fasteners shall be submitted to a fatigue test in conformance with 4.3.5.
- d. When threads are machined oversized and subsequently rolled, no evidence of machining shall be observed on the thread surface after rolling.

NOTE This applies for fasteners of large diameter.

- e. Thread rolling shall be carried out after heat treatment and machining of fasteners.

- f. Unless otherwise specified in the customer specification document for threaded fasteners, a single right-hand thread shall be obtained.
- g. The thread run-out portion of a bolt or stud shall consist in a progressive and regular junction with the shank avoiding sharp changes in section.
- h. Thread lead and run-out portions shall conform to the requirements in clause 4 of ISO 3353-1:2002.

4.1.7 Identification marking

- a. Fasteners shall be marked by depressed characters only with character size in conformance with the customer specification document for threaded fasteners and drawings.
- b. Characters for marking fasteners shall:
 - 1. be depressed no more than 0,25 mm from the surface;
 - 2. have rounded root form;
 - 3. be impressed on the upper surface of the fastener head.
- c. Marks shall univocally identify the fastener batch and supplier.
- d. Safe-life fasteners shall be identification marked separately after non-destructive inspection.

4.1.8 Surface treatment

- a. A surface treatment shall be selected:
 - 1. in order to improve surface characteristics and corrosion resistance,
 - 2. in accordance with the customer requirements for threaded fasteners.
- b. In surface plated fasteners, surface plating shall be applied to the entire fastener surface including the threaded portion.
 - NOTE Surface plating can cause tolerance variations.
- c. Silver plating shall not be used on titanium alloy fasteners.
 - NOTE Silver and cadmium plating are not used because they can cause embrittlement of titanium alloys, as per requirement in ECSS-Q-ST-70-71.
- d. Baking shall be carried out after electrolytic plating to prevent hydrogen embrittlement.
 - NOTE In fact, electrolytic plating processes generate hydrogen. This is achieved by choosing appropriately temperature and duration of the baking process.
- e. The baking temperature shall be selected such that the plating and substrate materials are not deteriorated.

4.1.9 Workmanship, handling and packaging

- a. Fasteners shall be free from burrs, tool marks, scale, other surface defects and contaminants.
- b. Fasteners shall be handled and packed during storage and transportation in the following way:
 1. pack fasteners of the same batch in unit packages;
 2. do not apply any protective lubricants or substances on fasteners unless otherwise specified in the customer specification document for threaded fasteners.

NOTE This is to prevent mechanical damage and contamination (e.g. from PVC or fibreboard).

- c. Each individual package shall be univocally identified by a durable and legible external marking indicating the product denomination, quantity, batch identification, manufacturer, product conformance report as in 4.4.2.5 and date of packing.
- d. Fasteners for safe-life applications shall be packed and stored separately.

4.2 Dimensional and metallurgical requirements

4.2.1 General

- a. Dimensional and metallurgical controls shall be carried out in conformance with the sampling procedures and acceptance criteria specified in 4.4.2.1.
- b. Designation of dimensions and symbols shall be in conformance with in conformance with ISO 225:1998.
- c. Dimensional control of fasteners (bolts, nuts and studs) shall be carried out at room temperature (22 ± 3) °C.
- d. Gauges and measuring devices shall be in conformance with ISO 1502:1996.

4.2.2 Nominal dimensions

- a. Nominal dimensions shall be in conformance with the detail drawings of the customer specification document for threaded fasteners.
- b. All dimensions shall refer to the final product and include any dimensional modification subsequent to chemically applied or electroplated coating.
- c. ISO 1502:1996 on thread geometry and dimensions shall apply.
- d. Tolerances for fasteners shall be in conformance with national or international aerospace standards (e.g. LN, DIN aerospace standards) or meet or exceed tolerance values specified in ISO 4759-1:2000 for "Product grade A".

4.2.3 Head-to-shank fillet

- a. The value of distortion shall not exceed 0,03 mm above and below the profile lines at points A and B in Figure 4-1.

NOTE In bolts, cold rolling of head-to-shank fillets can cause distortion of fillet areas. Figure 4-1 shows the typical distortion of the head-to-shank fillet profile.

- b. The value of the extension C of the distorted area in Figure 4-1 shall not exceed the values indicated in Table 4-1.

4.2.4 Non-destructive inspections

- a. Fasteners shall be free from surface defects such as flaws and inclusions.
- b. Inspections on bolts, studs and screws shall be carried out by using liquid penetrant or magnetic particles in conformance with ASTM E 1417-1999 and ASTM E 1444-2001, respectively.
- c. Non-destructive inspections shall be carried out by qualified personnel.
- d. Fasteners for safe-life applications shall be inspected as follows:
1. using a 100 % batch inspection plan;
 2. by X-ray, ultrasonic or eddy current inspection methods to obtain 95 % (minimum) confidence level and 90 % (minimum) probability of defect detection.
- e. For fasteners for safe-life applications the results of NDI shall be evaluated in conformance with ECSS-E-ST-32-01.
- f. Fasteners with detected surface defects shall be visually re-examined at $\times 15$ (minimum) magnification factor.

NOTE An accurate measurement of the defect size can be obtained by metallographic examination in conformance with 4.2.5.

- g. The following fasteners shall be declared as nonconformant:
1. fasteners for fail-safe applications if the size of any defect is larger than the size specified in ISO 6157-2:1995 and ISO 6157-3:1988;
 2. fasteners for safe-life applications if the size of any defect is larger than the size specified ECSS-E-ST-32-01.

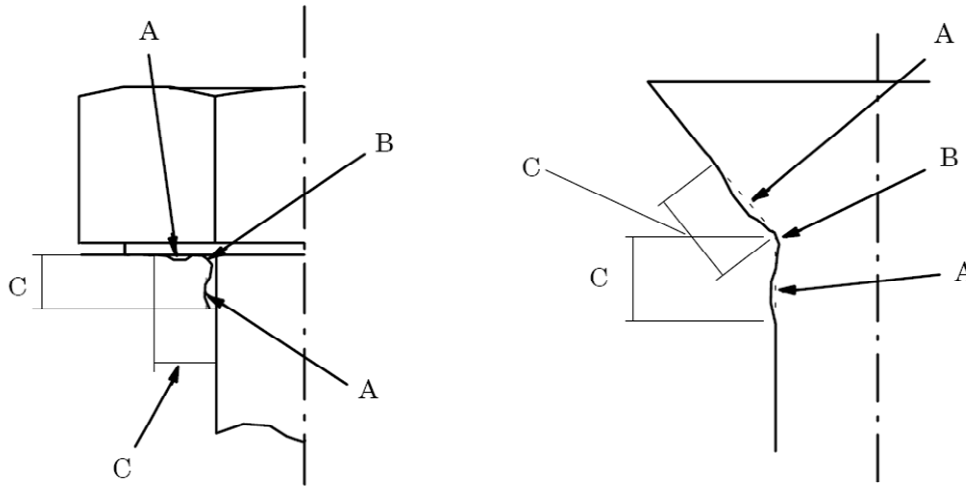

Figure 4-1: Tolerance of head-to-shank fillet profile

Table 4-1: Maximum allowed values of the extension C of the distorted area shown in Figure 4-1

Nominal diameter, d (mm)	$d < 5$	$5 \leq d \leq 7$	$8 \leq d \leq 10$	$11 \leq d \leq 16$	$17 \leq d \leq 24$	$d > 24$
C maximum (mm)	1,00	1,5	2,5	3,5	4,5	5,0

4.2.5 Metallurgical examination

- a. Fasteners selected for metallurgical examination shall be cut and prepared for observation in conformance with state-of-the-art standard laboratory practice.

NOTE Figure 4-2 shows the locations of microsections.

- b. Fasteners when visually examined at a magnification of between $\times 10$ and $\times 50$ shall exhibit a continuous grain flow in the head area and head-to-shank transition zone.
- c. Z values, in conformance with Figure 4-3, shall be equal to or less than the maximum fillet radius R ($Z \leq R_{\max}$) as specified in the detail drawings of the customer specification document for threaded fasteners.
- d. Fasteners when visually examined at a magnification of $\times 50$ shall exhibit continuous grain flow following the thread profile with maximum density of flow lines at thread roots.

NOTE For details see Figure 4-4.

- e. Fastener microstructure shall be visually inspected for internal defects at a magnification of $\times 100$ or higher in un-etched condition.
- f. Fastener microstructure shall be free from internal defects.
- g. Surface coated or plated fasteners shall exhibit adequate thickness, uniformity and integrity of the protective layer.

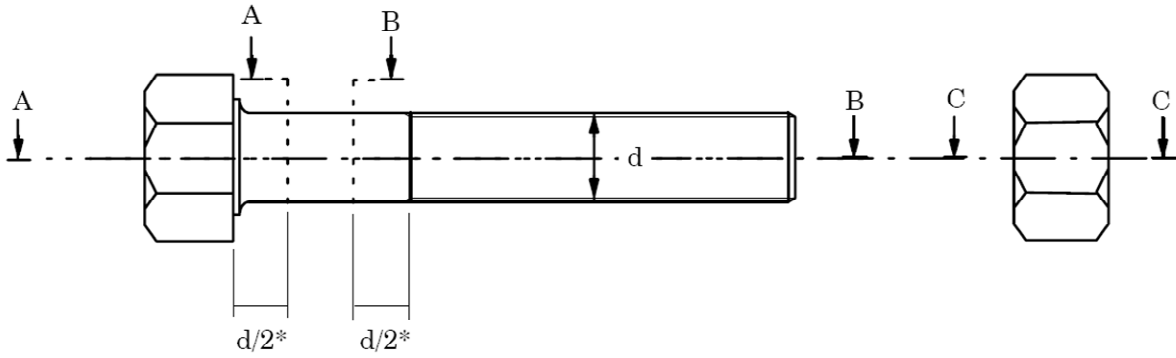

(*) minimum required

Figure 4-2: Location of microsections for metallurgical examination

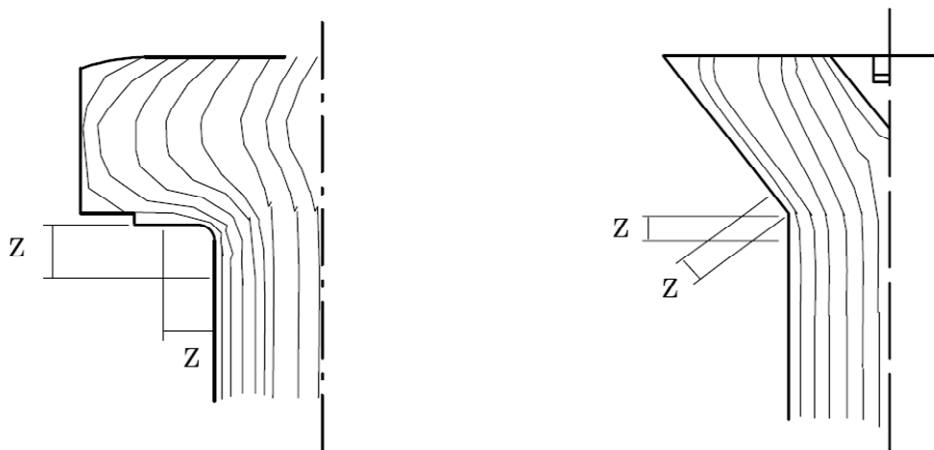

Figure 4-3: Area Z delimiting interruptions in grain flow in the head-to-shank region

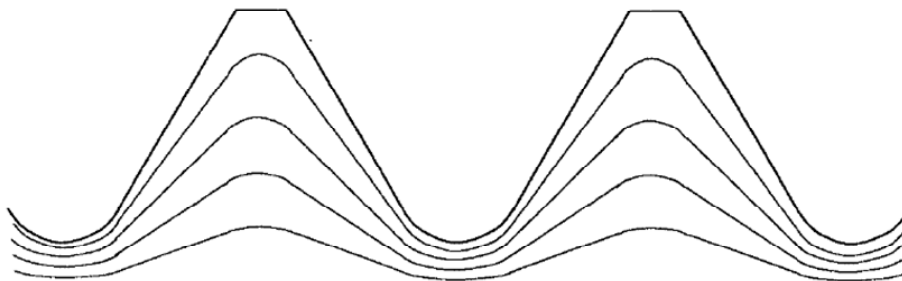

Figure 4-4: Example of a regular grain flow in a threaded surface

4.2.6 Measurement of hydrogen content

- a. Embrittlement by hydrogen absorption shall be prevented.

NOTE Hydrogen contamination can cause embrittlement and degradation of mechanical properties of metals.

- b. Hydrogen content in fasteners shall be measured by an approved vacuum fusion or vacuum extraction method.

NOTE Samples of material can be extracted from the fastener head after the removal of any surface coating.

- c. Hydrogen content in fully finished fasteners made of Titanium alloys shall not exceed 0,0125 %.

NOTE Titanium alloys are particularly prone to embrittlement by hydrogen absorption.

4.2.7 Outgassing and offgassing

- a. Thermal vacuum outgassing test in conformance with ECSS-Q-ST-70-02 shall be carried out on fasteners with organic inserts or collars, lubricants or protective substances if exposed to vacuum during service.

- b. Offgassing test in conformance with ECSS-Q-ST-70-29 shall be carried out on fasteners with organic inserts or collars, lubricants or protective substances if used in crew compartments of manned space vehicles.

4.3 Mechanical testing

4.3.1 General

- a. With the exception of the cases covered in 4.3.6, 4.3.7 and 4.3.8, mechanical testing for quality control purposes shall be performed at room temperature (22 ± 3) °C and laboratory air, (55 ± 10) % relative humidity.

- b. Mechanical properties of fasteners shall be in conformance with the specifications in the customer specification document for threaded fasteners.

- c. Mechanical testing shall be carried out in conformance with the sampling procedures and acceptance criteria specified in 4.4.2.3.

- d. Fasteners shall be retained in an approved quarantine facility for record or traceability purposes or destroyed in conformance with company practice after mechanical testing.

NOTE The test methods specified in this Standard are intended for quality control and acceptance only, ensuring that fastener properties are within the limit values specified in the customer specification document for threaded fasteners.

4.3.2 Hardness test

4.3.2.1 General

- a. Hardness tests shall be carried out in conformance with:
 1. the Brinell Hardness Test (HB) in conformance with ISO 6506-1:1991; ISO 6506-2:1999, ISO 6506-3:1999, or
 2. the Vickers Hardness Test (HV) in conformance with ISO 6507-1:1997, ISO 6507-2:1997, ISO 6507-3:1997, or
 3. the Rockwell Hardness Test (HRC) in conformance with ISO 6508-1:1999, ISO 6508-2:1999, ISO 6508-3:1999.
- b. Measured hardness values shall conform to the hardness values specified in the customer specification document for threaded fasteners.

4.3.2.2 Method

- a. Hardness tests on fasteners shall be carried out on the circular surface at the end of the threaded portion of the fastener shank after removing any surface coating.
- b. For fasteners with nominal diameter greater than 6 mm, hardness shall be measured in the centre of the circular surface and at two other locations at different distances from the centre of the surface, Figure 4-5.
- c. For short fasteners which cannot be tensile tested (usually with a grip length less than twice the nominal diameter), the following steps shall be performed:
 1. carry out Vickers hardness measurements on a longitudinal microsection of the shank;
 2. measure hardness along the shank longitudinal axis.
- d. When deemed necessary to check the heat treatment batch homogeneity by hardness testing, hardness tests shall be carried out after the completion of any heat treatment and before any rolling operation.

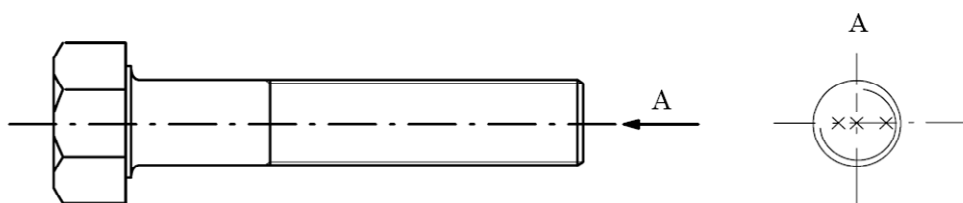

Figure 4-5: Locations for hardness testing (indicated with cross symbol)

4.3.3 Tensile test

4.3.3.1 Preconditions

- a. The tensile test method in 4.3.3.2 shall apply to finished fasteners having:
 1. a protruding head with grip length equal or greater than twice the nominal diameter, or

2. a countersunk head and an overall length equal or greater than three times the nominal diameter, or
3. a minimum length of 18 mm.

4.3.3.2 Method

- a. Test jigs shall be designed and manufactured in conformance with ISO 3800:1993.
- b. Test jigs shall ensure a tensile loading parallel to the fastener main axis.
- c. No torsional stress shall be induced by the assembly.
- d. Specimens shall be assembled freely in the fixture without bending or forcing.
- e. The bearing face of the threaded part of the jig, Figure 4-6 (a), or of the nut, Figure 4-6 (b), shall be located at least four pitches of distance from the unthreaded portion of the shank.
- f. The nut threads shall be fully engaged.
- g. A bolt length of at least two pitches shall protrude beyond the threaded part of the jig, Figure 4-6 (a), or the test nut, Figure 4-6 (b).
- h. Test nuts shall be used only once.
- i. When tested separately, axial load test of nuts shall be in conformance with clause 3.3 of ISO 9140:1998.
- j. Speed of testing shall be defined in terms of rate of separation of the two heads of the testing machine during a test.
- k. Speed of testing shall not exceed 25 mm/min.

NOTE Best practices is to maintain the speed of testing between 0,5 mm/min and 1,0 mm/min.
- l. Static failure shall only be tolerated in the shank.
- m. Fasteners with static failures occurring at the head-to-shank fillets shall be identified as nonconformant.
- n. The yield and ultimate tensile load of a tested fastener shall not be less than the values specified in the customer specification document for threaded fasteners.
- o. The cross sectional area, S , used in the interpretation of the tensile test results, expressed in mm², shall be assumed as the minimum of the two values S_1 and S_2 given by:

$$s_1 = \frac{\pi}{4} (d_3)^2 \left[2 - \left(\frac{d_2}{d_3} \right)^2 \right], \text{ or}$$

$$s_2 = \frac{\pi}{4} \phi_{\min}^2$$

where:

d_2 is the nominal pitch diameter in mm;

d_3 the thread root nominal diameter in mm; and

ϕ_{\min} the diameter of the minimum fastener cross sectional area if not in the threaded portion.

4.3.4 Shear test

4.3.4.1 Preconditions

- a. The shear test method in 4.3.4.2 shall apply to:
 - 1. finished fasteners of all sizes which meet one of the three requirements as specified in 4.3.3.1;
 - 2. fasteners with stepped threads (shouldered fasteners).

4.3.4.2 Method

- a. Shear test shall be carried out in double-shear loading configuration.

NOTE Figure 4-7 shows an example of double-shear loading jigs.
- b. The shear loads to failure shall be no less than the allowable values specified in the customer specification document for threaded fasteners.

4.3.5 Fatigue test

4.3.5.1 General

- a. Fatigue tests shall be carried out in conformance with ISO 3800:1993.

4.3.5.2 Preconditions

- a. The fatigue test method in 4.3.5.3 shall apply to finished fasteners of all sizes which meet one of the three requirements as specified in 4.3.3.1.

4.3.5.3 Method

- a. Fasteners shall be loaded in tension in conformance with one of the loading schemes shown in Figure 4-5.
- b. The fatigue test conditions shall be specified in the customer specification document for threaded fasteners in terms of:
 - 1. type of load fluctuation (sinusoidal unless otherwise agreed);
 - 2. stress range in MPa;
 - 3. stress ratio (R);
 - 4. frequency of load fluctuation in Hertz;
 - 5. specified mean and minimum fatigue life in cycles.
- c. The frequency of load fluctuation shall be
 - 1. between 4 Hz and 250 Hz,
 - 2. such that the temperature of the test specimen measured at the first engaged thread is always less than 50°C.
- d. Stress calculation shall be based on the expressions for fastener cross sectional area given in 4.3.3.
- e. Fatigue strength values shall be determined in the finite life range (failure of all test pieces before a predetermined number of stress cycles is reached) and in the transition range where, up to a predetermined

number (typically 5×10^6 to 5×10^7) of stress cycles, failure as well as non-failure occurs.

- f. All the tested fasteners shall exceed the minimum number of cycles specified for each applied stress range in the customer specification document for threaded fasteners.
- g. For fasteners with fatigue lives less than the expected mean fatigue life, failure shall not occur in the head-to-shank fillet.

NOTE No restrictions in failure location apply for fasteners with fatigue lives exceeding the expected mean fatigue life.

4.3.6 Creep test

4.3.6.1 General

- a. The creep tests shall be carried out in conformance with ISO 204:1997.
- b. Calculations shall be based on the expressions for fastener cross sectional area given in 4.3.3.2o.

NOTE 1 Creep test is particularly recommended for Titanium alloy fasteners.

NOTE 2 For details see Annex B.

4.3.6.2 Method

- a. The percent elongation after fracture, the reduction of area at failure and the time to fracture shall be within the values specified in the customer specification document for threaded fasteners.

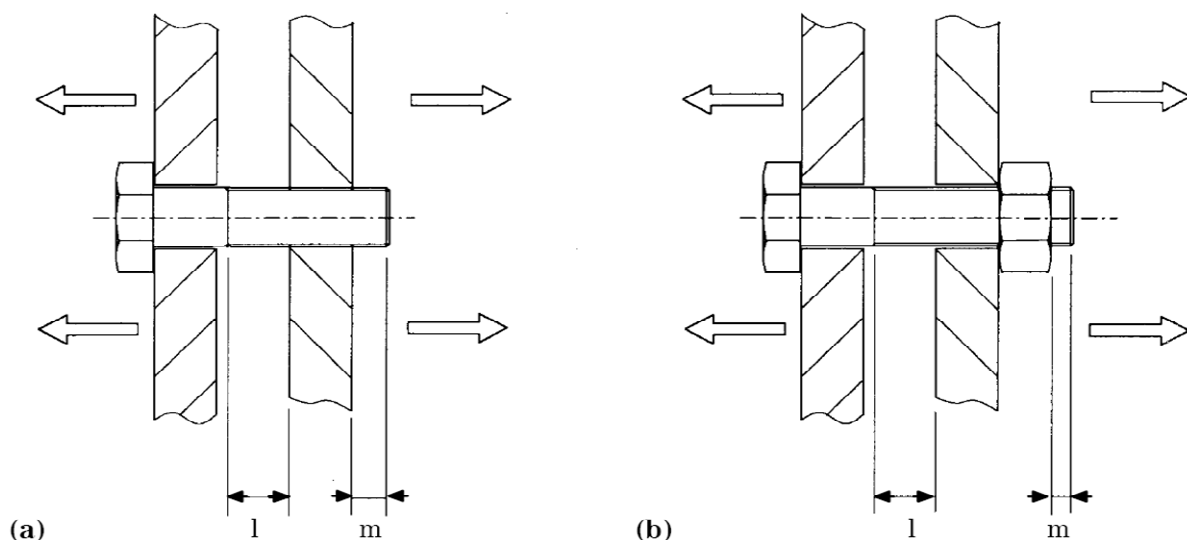

($l \geq$ four times the thread pitch and $m \geq$ two times the thread pitch)

($l \geq$ four times the thread *pitch* and $m \geq$ two times the thread *pitch*)

Figure 4-6: Loading schematic for tensile testing of threaded fasteners

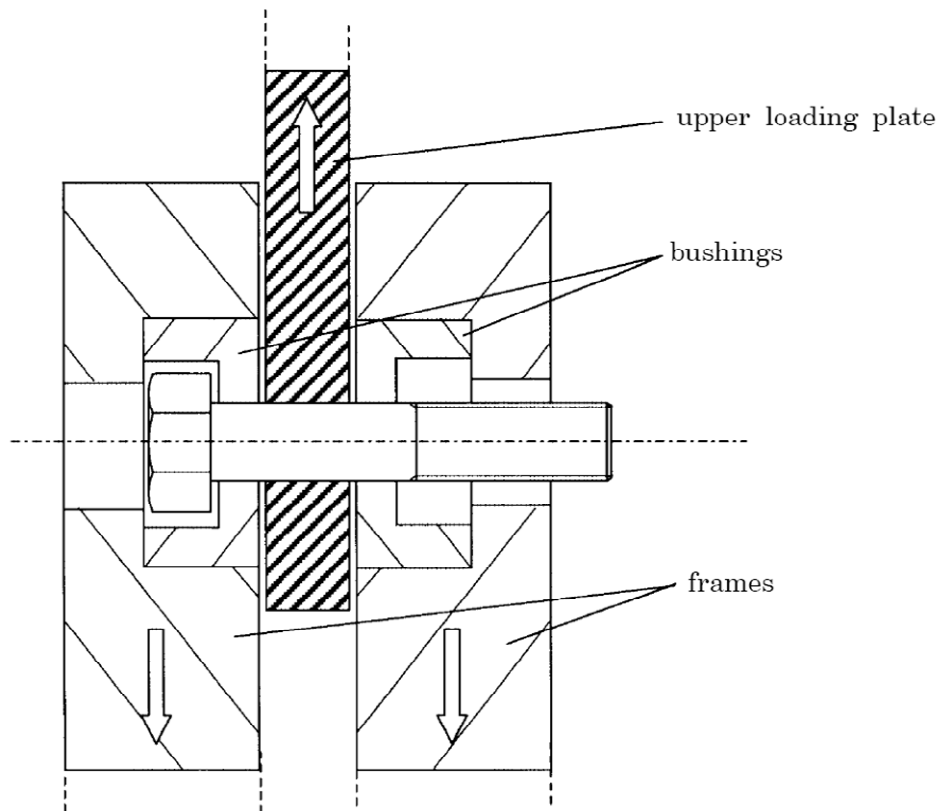

Figure 4-7: Schematic of an example of double-shear loading jigs

4.3.7 Corrosion test

4.3.7.1 General

- a. Fasteners shall be tested for corrosion in conformance with ASTM B 117-1997.

4.3.7.2 Method

- a. Sample geometry, exposure time and acceptance criteria shall conform to the requirements specified in the customer specification document for threaded fasteners.
- b. Metallic fasteners shall not be in contact with carbon fibre composite materials.

NOTE The reason is the considerable risk of corrosion.

4.3.8 Stress-corrosion test

- a. Stress-corrosion testing shall be carried out in conformance with ECSS-Q-ST-70-37.

4.4 Quality assurance

4.4.1 General

- a. The supplier shall implement the quality assurance, inspection and quality control procedures specified herein before any supply activity.
- b. The implementation of the procedures shall be maintained for the entire duration of the business agreement.

4.4.2 Quality requirements

4.4.2.1 General

- a. The supplier shall establish and implement adequate quality control actions and inspections to provide evidence of conformity to the product requirements.

NOTE Quality control actions and inspections can be performed by the supplier or by different companies (e.g. manufacturers, test houses and external laboratories) entirely under the supplier's direct responsibility.

- b. The supplier shall have a quality assurance system.

NOTE For example ISO 9001 can be applied.

- c. The supplier shall not use fasteners manufactured more than 10 years before use in space hardware.

NOTE The reasons are possible time-dependent degradation phenomena (e.g. corrosion, stress corrosion, design modifications, improvements in materials and manufacturing processes).

4.4.2.2 Quality control of materials

- a. Selection and control of suitable materials for fastener fabrication shall be based on the requirements defined in ECSS-Q-ST-70-71.
- b. The supplier shall provide evidence that only materials in conformance with the customer specification document for threaded fasteners are used in the fabrication.
- c. The supplier shall issue a raw material certificate (RMC) specifying: material standard designation, heat treatment, form, manufacturer, batch number, batch chemical analysis, batch tensile test results (0,2 % proof stress, ultimate stress and elongation) and batch hardness value.
- d. In the case where NDI is requested in the customer specification document for threaded fasteners, the supplier shall include in the RMC the date of the NDI, name of inspector, NDI results with description of any nonconformance.

4.4.2.3 Sampling procedure

- a. The supplier in agreement with the customer shall determine a sampling procedure in conformance with:
 1. ISO 2859-1:1999 for batch-by-batch inspections; or
 2. ISO 2859-2:1985 for isolated batch inspections.
- b. The supplier shall specify the selected sampling procedure in the customer specification document for threaded fasteners by defining a sampling plan.
- c. The supplier shall define the batch acceptability criteria in terms of:
 1. acceptance quality limit (AQL), if the batch-by-batch inspection method is selected, or
 2. limiting quality (LQ), if the isolated batch inspection is selected.
- d. The supplier shall define sample size in terms of inspection levels.

NOTE Table C-1 gives the recommended inspection levels, LQ and AQL values to be used.
- e. The supplier shall draw the specified sample units at random from the batch.

NOTE A batch of fasteners is a set of fasteners of the same type and diameter, obtained from the same batch of raw material, manufactured by the same process and heat treated as one batch.
- f. The supplier shall accept the batch only if the number of nonconforming units is less or equal to the acceptance level specified in the customer specification document for threaded fasteners.
- g. The supplier shall reject any nonconforming units found during batch inspection.

4.4.2.4 Nonconforming batches

- a. In the case where the number of nonconforming units is greater than the acceptance level specified in the customer specification document for threaded fasteners, the supplier shall reject the batch.
- b. The supplier shall subject re-submission for inspection of rejected batches to the customer approval.
- c. The customer shall determine the method of acceptance to be applied to re-submitted batches.
- d. In re-submitted batches, the supplier shall re-examine or re-test all units in the batch.
- e. The supplier shall remove all nonconforming units or replace them by conforming units.
- f. On re-submission, the supplier shall indicate the nonconforming batches as re-submitted specifying the cause for previous nonconformance.
- g. The supplier shall subject batches of fasteners for safe-life applications to NDI in all their units.

4.4.2.5 Product conformance report

- a. The supplier shall issue a product conformance report (PCR), in conformance with the DRD in Annex B, for each delivered batch of fasteners.
- b. The supplier shall deliver the PCR to the customer together with the batch of fasteners.

4.4.2.6 Incoming inspection

- a. On delivery the customer shall carry out an incoming inspection of the batch.
- b. The customer shall establish if the information given in the PCR is complete, clear and satisfactory.
- c. The customer shall verify that the fastener identification marks are consistent with the information given in the PCR.
- d. For structural fasteners with nominal diameters larger than 4 mm (M4) which are not directly procured from a fastener manufacturer (i.e. procured through a distributor or supplier), the customer shall carry out: dimensional check, tensile test, chemical analysis, hardness test and non-destructive inspections in conformance with 4.2.4.

NOTE A structural fastener is a fastener used in either the primary or secondary load path of a structure.

- e. Sampling procedure shall be in conformance with 4.4.2.3.
- f. Only qualified test laboratories shall carry out the tests.
- g. The supplier shall provide evidence that the batch conforms to the customer specifications.

Annex A (normative)

Customer specification document for threaded fasteners – DRD

A.1 DRD identification

A.1.1 Requirement identification and source document

This DRD is called from ECSS-Q-ST-70-71 requirement 4.1.1a.

A.1.2 Purpose and objective

Within the contractual relation between the customer and the supplier, the customer specification document for threaded fasteners specifies the technical and quality requirements, and the criteria and procedures to be used to assess the fulfilment of such requirements. The customer specification document for threaded fasteners is prepared by the customer, who sets the technical and quality requirements, in collaboration with the supplier, who agrees to the requirements and procedures.

This DRD does not define format, presentation or delivery requirements of the customer specification document for threaded fasteners.

A.2 Expected response

A.2.1 Scope and content

<1> Specifications

- a. The document shall specify the following items:
 1. The selected raw material in terms of: standard designation, heat treatment, form, minimum mechanical properties (hardness, 0,2 % proof stress, UTS, elongation and toughness).
 2. The complete fastener manufacturing process in terms of all the single operations required from the raw material to obtain the finished product.

3. The nominal dimension, tolerance and geometry of the finished fastener.
4. Indication of fastener designation and thread type.
5. Technical drawings enclosed to the customer specification document for threaded fasteners.
6. Surface treatment of finished fasteners.
7. Minimum hardness values of finished fasteners.
8. Tensile mechanical properties of finished fasteners in terms of: load to yield, ultimate load and elongation to failure.
9. Minimum shear load to failure of finished fasteners.
10. Minimum and mean required fatigue strength of finished fasteners in terms of stress range versus fatigue cycles (S-N curves) at specified constant stress ratios.
11. Minimum creep properties of finished fasteners in terms of elongation, reduction of area and time to failure.
12. Corrosion requirements in terms of exposure time and acceptability criteria (maximum number and density of corrosion pits).
13. Stress-corrosion testing if requested.
14. Definition of mechanical test methods and conditions for 7 until 13 in conformance with the relevant clauses of this Standard and other applicable standards.
15. Quality control plan in terms of: identification marking, sampling procedure, sampling plan and non-destructive inspection (NDI) plan.
16. Definition of procedures and time schedule for handling, storage, transportation and delivery.

A.2.2 Special remarks

None.

Annex B (normative)

Product conformance report (PCR) – DRD

B.1 DRD identification

B.1.1 Requirement identification and source document

This DRD is called from ECSS-Q-ST-70-71 requirement 4.4.2.5a.

B.1.2 Purpose and objective

This DRD defines the content of the Product conformance report.

B.2 Expected response

B.2.1 Scope and content

<1> Contents

- a. The PCR shall indicate:
 1. batch supplier name/code;
 2. date of batch manufacturing;
 3. purchase order form;
 4. raw or semi-finished material supplier name/code;
 5. date of raw or semi-finished material production;
 6. batch identification number and fastener identification marks;
 7. reference to fastener specifications;
 8. the raw material certificate (RMC) including a report of quality the inspections (destructive and non-destructive) carried out on the raw or semi-finished material as specified in this document;
 9. report of the fasteners quality control inspections (destructive and non-destructive) as specified in this document;
 10. report of conformance/nonconformance and corrective actions;
 11. any other relevant documentation.

B.2.2 Special remarks

None.

Annex C (informative)

Inspection levels, acceptance quality limits (AQL) and limiting quality levels (LQ) for inspection of fasteners

Table C-1: Inspection levels, acceptance quality limits (AQL) and limiting quality levels (LQ) for inspection of fasteners

Inspection method	High-strength steel	Stainless steel	Titanium alloys	Alloys for high temperature applications
Hardness test	Inspection level S-3, AQL 0,65 LQ 5,0 %	Inspection level S-3, AQL 0,65 LQ 5,0 %	–	Inspection level II, AQL 0,65 LQ 2,0 %
Dimensional and surface control	Inspection level II, AQL 0,65 LQ 2,00 %	Inspection level II, AQL 0,65 LQ 2,00 %	Inspection level II, AQL 0,65 LQ 2,00 %	Inspection level II, AQL 0,65 LQ 2,0 %
Microstructural examination and chemical analysis	Inspection level S-1, AQL 1,5 LQ 12,5 %	Inspection level S-1, AQL 1,5 LQ 12,5 %	Inspection level S-1, AQL 1,5 LQ 12,5 %	Inspection level S-1, AQL 1,5 LQ 12,5 %
Inspection for surface defects by NDI	Inspection level II, AQL 0,065 LQ 0,5 %	Inspection level II, AQL 0,065 LQ 0,5 %	Inspection level II, AQL 0,065 LQ 0,5 %	Inspection level II, AQL 0,065 LQ 0,5 %
Inspection for surface defects by NDI – Safe-life applications	100 % batch inspection	100 % batch inspection	100 % batch inspection	100 % batch inspection
Tensile test	Inspection level S-1, AQL 1,5 LQ 12,5 %	Inspection level S-1, AQL 1,5 LQ 12,5 %	Inspection level S-3, AQL 1,0 LQ 8,0 %	Inspection level S-1, AQL 1,5 LQ 12,5 %
Shear test	As specified by the customer (*)	As specified by the customer (*)	As specified by the customer (*)	As specified by the customer (*)
Corrosion test	As specified by the customer (*)	As specified by the customer (*)	As specified by the customer (*)	As specified by the customer (*)

Inspection method	High-strength steel	Stainless steel	Titanium alloys	Alloys for high temperature applications
Stress-corrosion test	As specified by the customer	As specified by the customer	As specified by the customer	As specified by the customer
Fatigue test	As specified by the customer (*)	As specified by the customer (*)	As specified by the customer (*)	As specified by the customer (*)
Creep test	As specified by the customer (*)	As specified by the customer (*)	As specified by the customer (*)	As specified by the customer (*)
Hydrogen content	As specified by the customer (*)	As specified by the customer (*)	Inspection level S-1, AQL 2,5 LQ 20,0 %	As specified by the customer (*)
Outgassing	As specified by the customer	As specified by the customer	As specified by the customer	As specified by the customer
Offgassing	As specified by the customer	As specified by the customer	As specified by the customer	As specified by the customer
(*) Test carried out on customer request.				

Bibliography

ISO 9001:2000	Quality management systems - Requirements
ECSS-S-ST-00	ECSS System – Description , implementation and general requirements